

# PCA SERIES

## 0.5 - 1.5 HP Packaged Chillers



## Technical Data Sheet

PCA Series Packaged Chiller by AEC are specially engineered for small, demanding industrial applications. Each self-contained unit is designed for immediate hook-up and is ready to supply clean, cooling water at constant temperatures. A wide range of economical options are available to meet or exceed the demands of almost any application.

Control within +/- 2°F (1.1°C) is achieved using microprocessor based PID controls with autotuning capability. NEMA 1-style electrical enclosures, non-ferrous wetted surfaces, and all refrigerant safeties. In order to conserve valuable floor space, the PCA chillers offer a space-saving footprint of 20" wide x 26" deep.

### Features

#### Standard Features

- Leaving water temperature range 35°F to 65°F (1.6°C to 18.3°C)
- 0.5 and 1.0 hp: hermetic reciprocating compressors
- 1.5hp: Hermetic scroll compressor
- Highly efficient tube-in-tube evaporators
- Aluminum fin/copper tube condensers
- Six (6) gallon (22.7 liter) polyethylene tank with external fill/drain sight glass
- Non-ferrous piping
- Regenerative turbine, horizontally mounted pump
- Microprocessor based PID controller with autotuning and To Process and Set Point LED readout
- Pressure-actuated process water bypass valve for system protection
- To Process 2.5" (63 mm) diameter, dual scale liquid-filled water pressure gauge
- Fully insulated refrigeration and process piping
- HFC-134a refrigerant
- NEMA 1 electrical enclosure
- Fully insulated pump and evaporator
- High and low refrigerant pressure safety switches
- Hot gas bypass capacity control
- Thermal expansion valve
- Refrigerant sight glass and filter dryer
- Ease of maintenance with multiple refrigeration access ports
- 1 year warranty on parts

#### Optional Features

- Graphic display package:
  - Pump Status
  - Compressor Status
  - Refrigerant Pressures
  - Hot gas bypass Status
- Increased operational capacity up to 75°F (23.9°C) with crankcase pressure regulating (CPR) valve
- General audible/visual alarm package with silence button
- Power cord (less plug)
- External Y-Strainer (shipped separately)
- Sight glass guard
- 4-year extended compressor warranty (factory startup is required)

## Product Diagrams

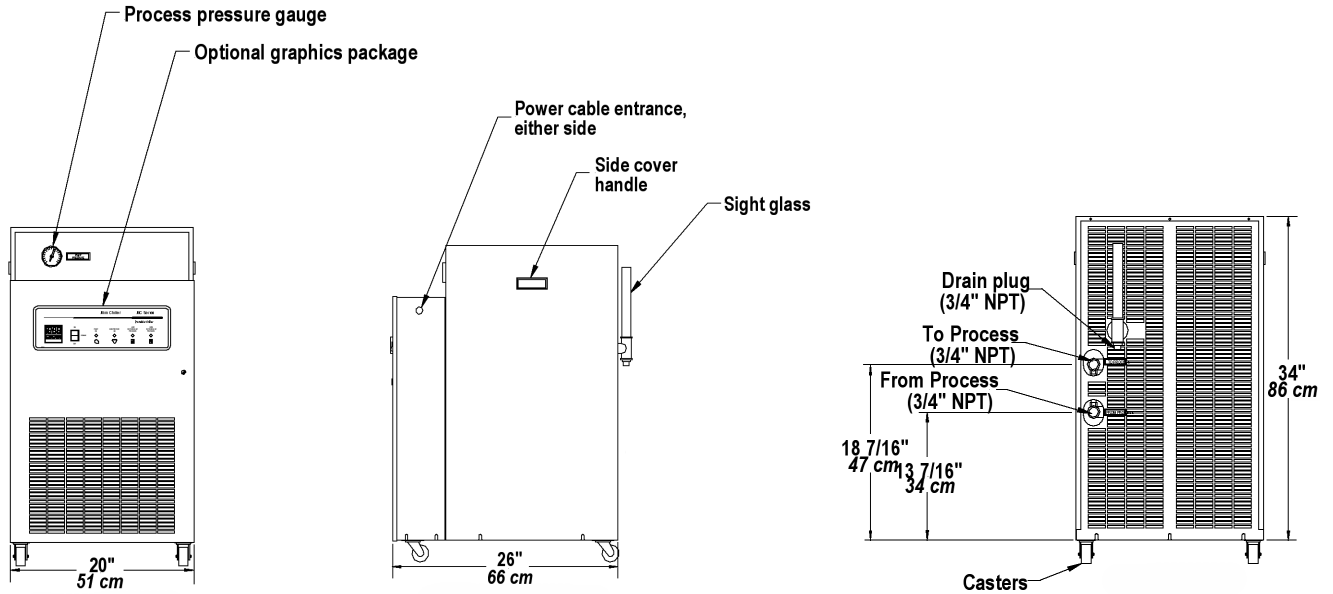

## Specifications

Model	Comp., HP (kW)	Standard Pump	Nominal chilled water, gpm (lpm)	Capacity @ 65°F (18°C) LWT, 75°F (24°C) ambient BTUH (tons)	Capacity @ 50°F (10°C) LWT, 90°F (32°C) ambient BTUH (tons)	Refrigerant	Process connection, in. NPT	FLA: weight, lbs. (kgs).	Oper. weight, lbs. (kgs).	Ship. weight, lbs. (kgs).
PCA 050	0.5 (0.373)	1.5 gpm @ 24 psig (4.5 lpm @ 207 kPa)	1.2 (4.5)	8100 (0.7)	4800 (0.4)	HFC 134A	0.75	10A	265 (121)	275 (125)
PCA 100	1 (0.746)	2.4 gpm @ 34 psig (9.0 lpm @ 234 kPa)	2.4 (9.0)	14000 (1.2)	9550 (0.8)	HFC 134A	0.75	13A	325 (148)	335 (153)
PCA 150	1.5 (1.12)	3.6 gpm @ 24 psig (13.6 lpm @ 165 kPa)	3.6 (13.6)	25400 (2.1)	16000 (1.3)	HFC 134A	0.75	19A	345 (157)	355 (162)

## Water Circuit Pressure Drop Table

Model	Gallons/Minute (gpm)	lpm	ΔP (psig)	ΔP (kPa)
PCA 050	2.0	7.5	2.5	17.3
	2.4	9.0	4.0	27.6
	3.6	13.6	7.5	51.8
	4.8	18.1	12.5	86.2
PCA 100	2.0	7.5	2.5	17.3
	2.4	9.0	2.5	17.3
	3.6	13.6	3.0	20.7
	4.8	18.1	5.0	34.5
PCA 150	2.0	7.5	2.5	17.3
	2.4	9.0	2.5	17.3
	3.6	13.6	3.0	20.7
	4.8	18.1	3.5	24.2