

MR SERIES

Single Shaft Shredders



Technical Specifications

MR Series Single Shaft Shredder are heavy duty single-shaft shredders featuring a push drawer. The MR Series Shredder is designed to shred heavy duty materials at a high volume including plastic blocks and sheets, polymer pipes, extruded sheets, medical plastic waste, electric cable, and rubber waste. This shredder features a hydraulic control for the pusher drawer to drive the material towards the blades for shredding. The MR Series Shredder can be used in-line for continuous shredding.

Features

Standard Features

- Throughput rate 440 up to 4,409 lbs/hr (200 to 2,000 kg/hr)
- Cutting Chamber sized: 23.62" x 27.6" (60cm x 70cm) up to 78.7" x 39.4" (200cm x 100cm)
- Safety features including emergency shut-off and drawer reversal system
- Roller bearings are sealed to protect against dust and liquids
- Blades of alloy steel to reduce wear
- Touch Screen controller with auto-regulation software to maximize shredding capabilities
- Controller alerts user to regularly scheduled maintenance requirements

Optional Features

- Injection molded runners and rejects
- Blow-molded parts and tops/tails
- Extruded tubes and profiles
- Edge trims from sheet extrusion

Specifications

Model	Throughput	Cutting Chamber	Power Installed Rotor	Rotor Diameter	Rotor Length
MR 22 - 60	440 to 880 lbs/hr (200 to 400 kg/hr)	23.6" x 27.6" (60cm x 70cm)	19 kW (25 hp)	8.7 in (22cm)	23.6 in (60cm)
MR 40 - 80	772 to 1763 lbs/hr (350 to 800 kg/hr)	31.5" x 39.4" (80cm x 100cm)	37 kW (50 hp)	15.6" (37cm)	31.1 in (79cm)
MR 40 - 100	992 to 2204 lbs/hr (450 to 1000 kg/hr)	39.4" x 39.4" (100cm x 100cm)	45 kW (60 hp)	15.8" (40cm)	39.4 in (100cm)
MR 40 - 120	1102 to 2645 lbs/hr (500 to 1200 kg/hr)	47.2" x 39.4" (120cm x 100cm)	55 kW (75 hp)	15.8" (40cm)	47.2" (120 cm)
MR 40 - 140	1322 to 3086 lbs/hr (600 to 1400 kg/hr)	55.1" x 51.2" (140cm x 130cm)	75 kW (102 hp)	15.8" (40cm)	55.1" (140 cm)
MR 48 - 200	1763 to 4409 lbs/hr (800 to 2000 kg/hr)	78.7" x 39.4" (200cm x 100cm)	55kW + 55 kW (75 hp + 75 hp)	18.9" (48cm)	78.7" (200cm)

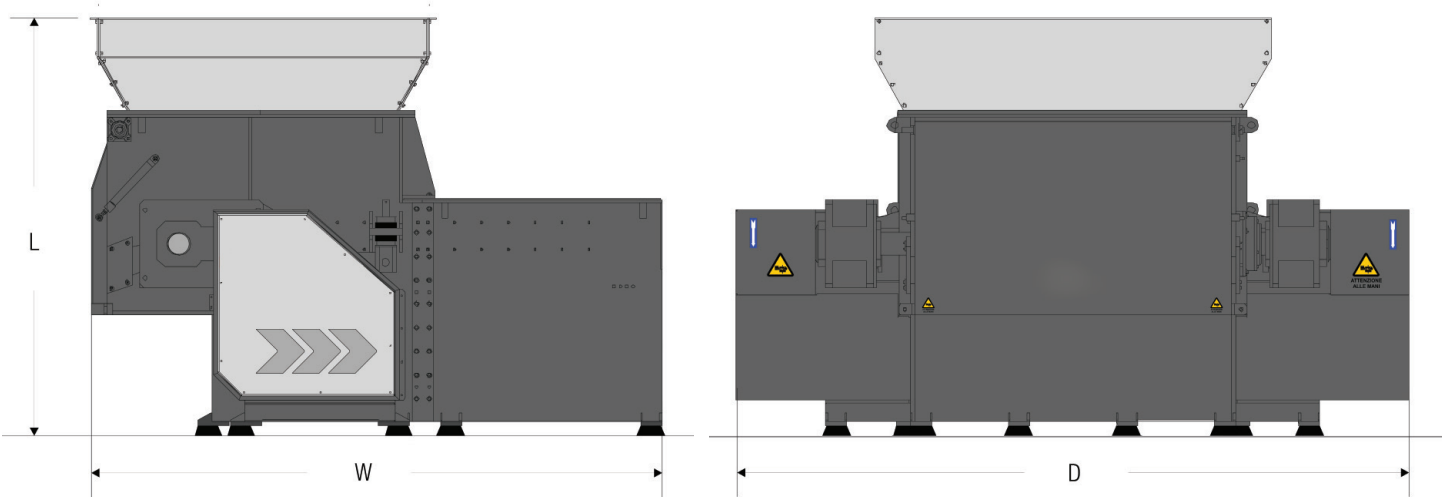

Model	Dimensions Length - Width - Depth	Weight
MR 22 - 60	66.4" x 68.9" x 50.8" (168cm x 175cm x 129cm)	3968 lbs (1800 kg)
MR 40 - 80	86.6" x 105.4" x 69.3" (220cm x 268cm x 176cm)	8,800 lbs (3992 kg)
MR 40 - 100	86.6" x 105.4" x 77.2" (220cm x 268cm x 196cm)	9,700 lbs (4,400 kg)
MR 40 - 120	86.6" x 105.5" x 98.4" (220cm x 268cm x 250 cm)	12,130 lbs (5,502 kg)
MR 40 - 140	86.6" x 105.5" x 110.4" (220cm x 268cm x 280cm)	23,100 lbs (10,478 kg)
MR 48 - 200	103.9" x 142.1" x 167.3" (264cm x 361cm x 425cm)	26,400 lbs (11,975 kg)