



SRH, SRC AND SRI VACUUM RECEIVERS

SR Series vacuum receivers from AEC feature a modular stainless steel design, offering significant operational advantages. The modular design allows these units to be economically reconfigured to accommodate future production requirements. Pyrex™ sight glass on SRI models allow for easy visual monitoring of material flow.

SRH/SRC vacuum receivers are used at each loading point in a central vacuum conveying system. **0.03, 0.1, and 0.2 cu. ft. receivers are not to be used on single line “Y” systems, and SRC04 receivers are not recommended. They should be used beside the machine or with dedicated lines.**



SRC Vacuum Receivers

STANDARD FEATURES

- Brushed stainless steel construction
- Material demand/level sensor
- Internal check valve on material inlet for 1.5", 2.0", 2.5" and 3.0" (not available on 0.03, 0.1, or 0.2 cu. ft. models)
- Removable **aluminum** inlets and outlets on most models
 - SRH 01 - stainless steel non-removable
 - SRC 02-04 - removable aluminum (1.5-2.5" O.D.)
 - SRC 08-16 - removable aluminum (1.5-3.5" O.D.)
 - SRC 30-60 - removable aluminum (2.0-4.0" O.D.)
 - SRC 30-60 - stainless steel welded, non-removable (4.5-5" O.D. sch. 10)
- SRC receivers include counter-weighted, angle discharge throat with throat gasket seal (SRH 01 - 1.5" throat, SRC 02-16 - 4" throat, SRC 30-60 - 6" throat)
- Stainless steel filter screen (10 mesh) (0.03–1.6 cu. ft. models), stainless steel pellet deflector (3.0–6.0 cu. ft. models)
- Vacuum outlet on side cover (SRH01 and SRC02-16 models)
- Vacuum outlet on top of cover - straight outlet (SRC30-60 models).
Note - optional outlets available for SRC 30-60
- Sight glass models feature Pyrex™ sight glass, 10-mesh stainless steel screen, and square flange. SRI04 includes check valve for single-line Y applications.

OPTIONAL REMOTE PROPORTIONING PACKAGE

- Includes proportioning valve, 2 aluminum pick-up wands, 2x10' vinyl flex hoses, 4 hose clamps, and controller assembly
- 1.5", 2", 2.5" OD inlet/outlet
- Hopper, floor stand, or wall mounting
- 115/1/60, 230/1/60, or 24 VDC supply voltage
- 115/1/60 or 24 VDC control voltage
- For 1.75" and 2.25" OD uses, use aluminum transitions/couplers (quote separately)

OPTIONAL FEATURES

- Volume-fill sensor, 180°F maximum, 24 VDC or 115 VAC control voltage (not available on 0.03–0.1 cu. ft. models)
- Stainless steel 20 mesh screen for micro-pellet applications
- Polyester cloth filter in lieu of standard screen/deflector
- Nylon filter in lieu of standard screen/deflector (150 mesh)
- OptiView riser assembly, flange mount, 150°F ambient max. temp. (not available on SRC 30/60)
- Machine-mount adapter for OptiView (or aluminum riser), square mounting flange (not available on SRC 30/60)
- Aluminum riser, flange-mount only (not available on SRH01 or SRI models)
- Silo-mount riser with gasketed, non-vented access door, part no. A0566986 (SRC 30/60 only)
- Aluminum riser with vented access door, part no. A0566987 (SRC 30/60 only)
- High-temperature (400°F) silicone discharge throat gasket (not available on 0.03–0.1 cu. ft. models)
- White neoprene discharge throat gasket, FDA approved, 180°F max. (not available on 0.03–0.1 cu. ft. models)
- 90° vacuum outlets (SRC 30/60 only)
- Adapter to fit TF/VF mounting hole, (18" dia. to 15" dia. BC, part. no. A0569579 (SRC 30/60 only)
- 70° cone for hard to flow materials in lieu of standard (special order only)
- Vibrating pads for 70° cone section (special order only)
- 253mm O.D. mounting flange (no bolt pattern) for SRC02-16 in lieu of standard flange part no. 822.00616.00

SPECIFICATIONS

Model	Receiver Capacity cu. ft. (l)	Receiver Capacity lbs. (Kg)	Shipping Weight lbs. (Kg)	Standard inlet/outlet sizes	Sight Glass Capacity cu. ft. (l)	
SRH01	0.1 (2.8)	3 (1.5)	29 (13)	1.5 (38)	N/A	N/A
SRC02	0.2 (5.6)	6.0 (3.1)	31 (14)	1.5, 2 (38, 51)	N/A	N/A
SRC04	0.4 (11.3)	12.0 (6.3)	33 (15)	1.5, 2, 2.5 ¹ (38, 51, 64 ¹)	N/A	N/A
SRC08	0.8 (22)	25 (12.7)	40 (18)	2, 2.5, 3 (51, 64, 76)	N/A	N/A
SRC16	1.6 (45)	50 (25.4)	43 (20)	2, 2.5, 3, 3.5 ² (51, 64, 76, 89 ²)	N/A	N/A
SRC30	3.0 (85)	100 (45)	75 (34)	2.5, 3, 3.5, 4, 4.5 (64, 76, 89, 101, 114)	N/A	N/A
SRC60	6.0 (170)	200 (90)	95 (43)	2.5, 3, 3.5, 4, 4.5, 5 sch. 10 (64, 76, 89, 101, 114, 143)	N/A	N/A

1) includes 2.5" to 2" transition on inlet/outlet and 2" check valve on inlet 2) Includes 3.5" to 3" transition on inlet/outlet and 3" check valve on inlet

Model	Receiver Capacity cu. ft. (l)	Receiver Capacity lbs. (Kg)	Shipping Weight lbs. (Kg)	Standard inlet/outlet sizes	Sight Glass Capacity cu. ft. (l)	
SRI002	0.028 (0.79)	1 (.45)	15 (7)	1.5 (38)	0.01 (0.28)	0.34 (0.15)
SRI01	0.1 (2.8)	3.0 (1.5)	27 (13)	1.5 (38)	0.02 (0.57)	0.68 (0.31)
SRI02	0.2 (5.6)	6.0 (3.1)	47 (22)	1.5, 2 (38, 51)	0.09 (2.55)	3.25 (1.48)
SRI04	0.4 (11.3)	12.0 (6.3)	49 (23)	1.5, 2, 2.5 ¹ (38, 51, 64 ¹)	0.09 (2.55)	3.25 (1.48)



SRC Vacuum Receiver
Flange Mount



SRI Vacuum Receiver



Remote Proportioning Valve

DIMENSIONS

SRH and SRC Dimensions, in. (cm)									
Model	A	B	C	D	E	F	G	H ¹	J ²
SRH01	14.875 (38)	10.625 (27)	9.375 (24)	6.38 (16)	12 (31)	1.75 (4)	6.375 (16)	5.5 (14)	11 (28)
SRC02	16.75 (43)	11.5 (29)	9.50 (24)	5.5 (14)	12 (31)	4 (10)	9.125 (23)	N/A	11 (28)
SRC04	22.375 (57)	17.5 (45)	13.50 (34)	11.5 (29)	12 (31)	4 (10)	9.125 (23)	N/A	11 (28)
SRC08	26 (66)	20.125 (51)	17.625 (45)	11.625 (30)	12 (31)	4 (10)	14.125 (36)	N/A	11 (28)
SRC16	32.25 (82)	26.375 (67)	23.875 (61)	18.125 (46)	12 (31)	4 (10)	14.125 (36)	N/A	11 (28)
SRC30	46.56 (119)	39.21 (100)	N/A	25.75 (66)	16 (41)	6 (15)	20 (51)	N/A	15 (38)
SRC60	62.56 (159)	55.21 (140)	N/A	41.75 (106)	16 (41)	6 (15)	20 (51)	N/A	15 (38)

1) .312" (8 mm) dia. holes; 2 places, equally spaced

2) .312" (8 mm) dia. holes; 12 places equally spaced

General Notes:

0.03, 0.1, 0.2, 0.4, 0.8 and 1.6 cu. ft. models have vacuum outlet mounted on the side of the cover.

3.0 and 6.0 cu. ft. models have the vacuum outlet at the top of the cover.

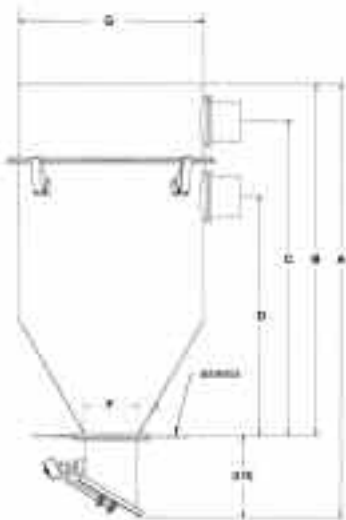

SRC16 Vacuum Receiver

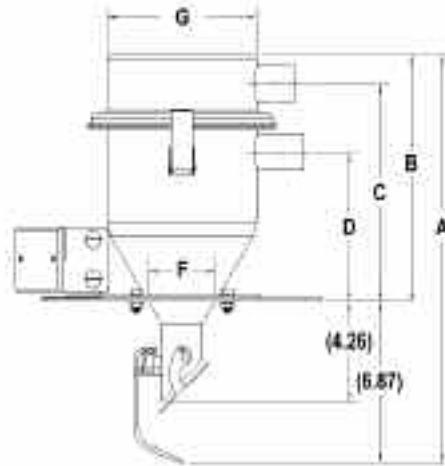

SRH01 Vacuum Receiver

Mounting Pattern - Flange Mount Configuration

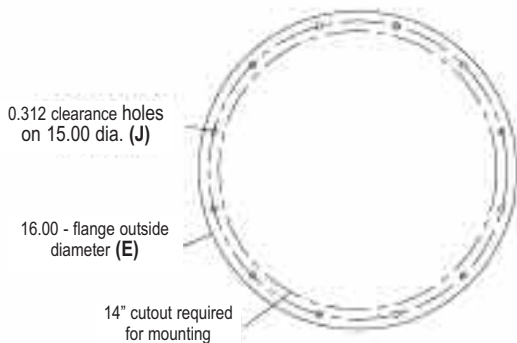

SRC30/60

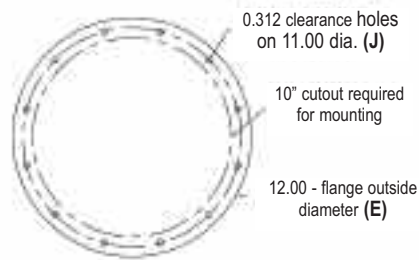

SRH01/SRC16

SRC30/60 VACUUM RECEIVER WITH RISER MOUNT OPTION

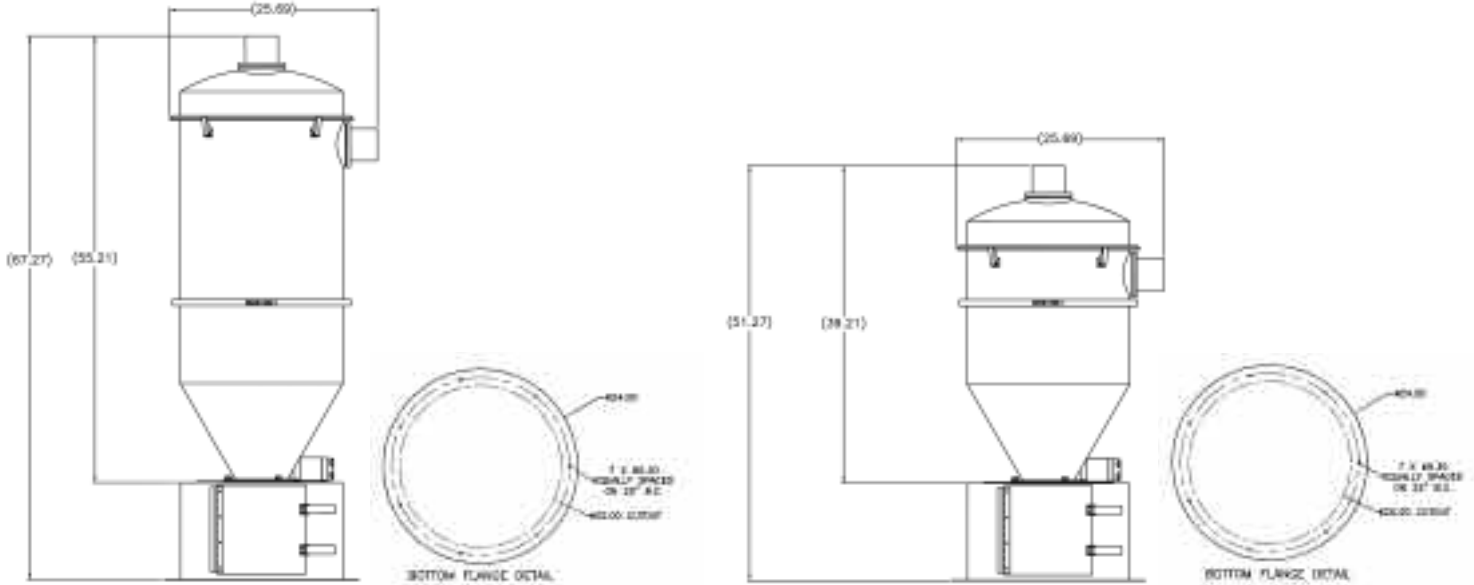

DIMENSIONS

SRI Dimensions, in. (cm)										
Model	A	B	C	D	E	F	G	H	I ²	J
SRI002	17.50 (44)	16.125 (42)	12.50 (32)	6.375 (16)	1.75 (4)	4 (10)	2 (5)	1.25 (3)	2.5 (6)	2 (5)
SRI01	21.25 (54)	20 (51)	16.625 (42)	6.375 (16)	1.75 (4)	4 (10)	2 (5)	1.25 (3)	2.5 (6)	2 (5)
SRI02	25.625 (65)	23.75 (60)	19.5 (50)	9.125 (23)	3 (8)	7 (18)	3.5 (9)	2.75 (7)	5.5 (14)	3 (8)
SRI04 ¹	31.5 (80)	29.625 (75)	25.5 (65)	9.125 (23)	3 (8)	7 (18)	3.5 (9)	2.75 (7)	5.5 (14)	3 (8)

¹ Model not shown 2 9/32" (7.14 mm) dia. holes; 4 places, equally spaced

